



Instrument Manifolds

Index

Safety Warning	Inside Front Cover
General Purpose Manifolds	
Overview	1
2-Valve	2
3-Valve	4
5-Valve	6
Mounting kits	8
Special Application Manifolds	
Trifold 3-Valve	9
Rotofold 3-Valve	12
Pentafold 5-Valve	15
Disclaimers	Inside Back Cover



instrument manifolds



CRANE Instrumentation & Sampling, HOKE®
PO Box 4866 • Spartanburg, SC 29305-4866
(864) 574-7966 • www.hoke.com

For Your Safety

It is solely the responsibility of the system designer and user to select products suitable for their specific application requirements and to ensure proper installation, operation, and maintenance of these products. When selecting products, the total system design must be considered to ensure safe, trouble-free performance. Material compatibility, product ratings and application details should be considered in the selection. Improper selection or use of products described herein can cause personal injury or property damage.

Contact your authorized HOKE® sales and service representative for information about additional sizes and special alloys.

SAFETY WARNING:

HOKE® products are designed for installation only by professional suitably qualified licensed system installers experienced in the applications and environments for which the products are intended. These products are intended for integration into a system. Where these products are to be used with flammable or hazardous media, precautions must be taken by the system designer and installer to ensure the safety of persons and property. Flammable or hazardous media pose risks associated with fire or explosion, as well as burning, poisoning or other injury or death to persons and/or destruction of property. The system designer and installer must provide for the capture and control of such substances from any vents in the product(s). The system installer must not permit any leakage or uncontrolled escape of hazardous or flammable substances. The system operator must be trained to follow appropriate precautions and must inspect and maintain the system and its components including the product(s) and at regular intervals in accordance with timescales recommended by the supplier to prevent unacceptable wear or failure.



General Purpose Instrument Manifolds at a Glance

HOKE® offers a variety of 2-,3-, and 5-valve instrument manifolds in direct and remote mount styles with vent configurations to meet most flow, pressure, and level measurement application requirements. HOKE® 2-valve manifolds are designed for static pressure and liquid level applications; the 3- and 5-valve manifolds are well suited for use with most differential pressure transmitters and can accept both female and flange process impulse line connections.

Valve Features

All valves are hydrostatically tested at 1.5X maximum working pressure to assure leak tight performance. Stem packing is available in PTFE or GRAFOIL® materials with the metal non-rotating stem tip offered as standard.

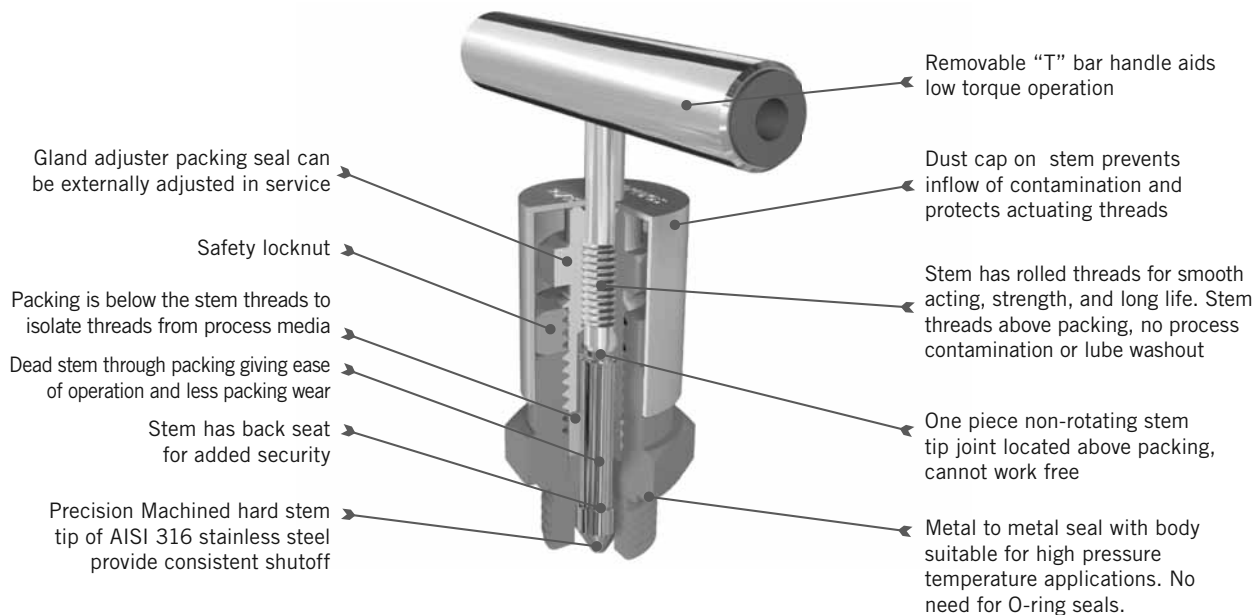

Pressure vs. Temperature Curves

PTFE PACKING*	Maximum pressure 6000 psi (413 bar) at 212° F (100° C) Maximum pressure 4000 psi (275 bar) at 392° F (200° C)
GRAFOIL® PACKING	Maximum pressure 6000 psi (413 bar) at 212° F (100° C) Maximum pressure 3300 psi (230 bar) at 842° F (450° C)

* PTFE packing rated to maximum temperature of 392° F (200° C)

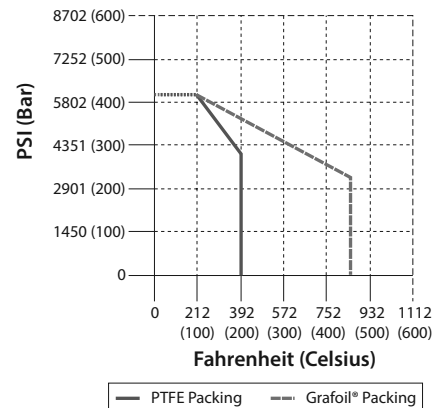

instrument manifolds

2-Valve General Purpose Manifold-Direct Mount

Dimensions

Dimensions in inches (millimeters) are for reference only and are subject to change.

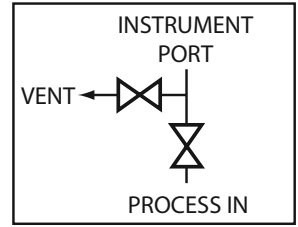

Front view

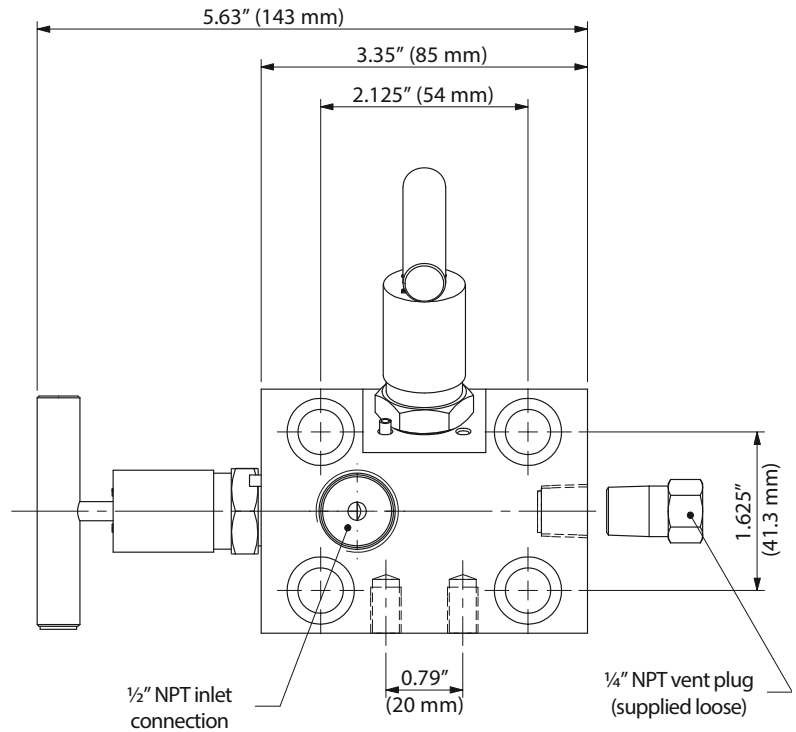

Right side view

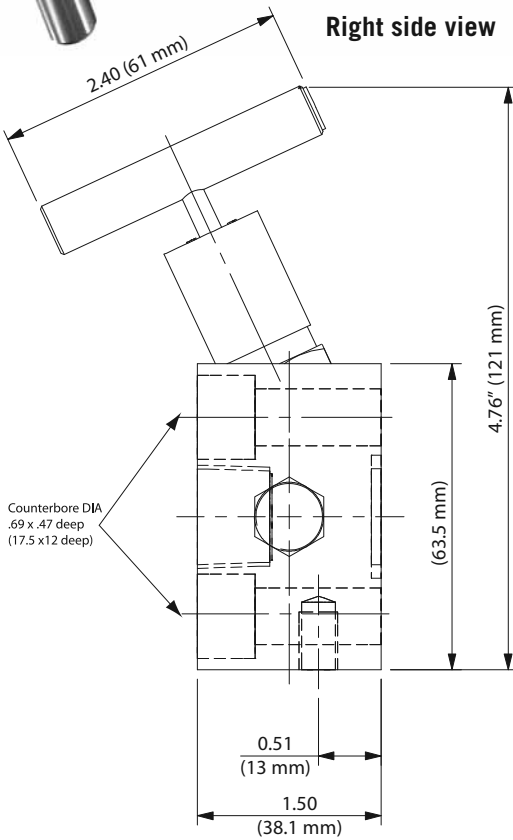

Back view

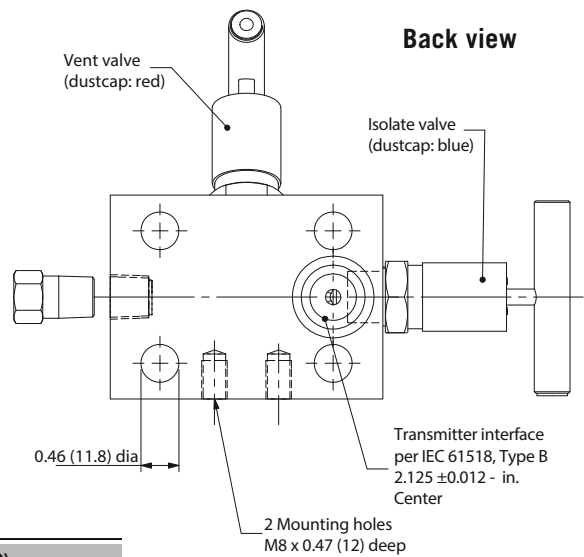

How to Order

PART NUMBER	PACKING	ACCESSORIES (NOT INCLUDED)
GP82121F8YL	PTFE	Mounting kit-Part # 800000K1 (page 8)
GP821212F8YL	GRAFOIL®	1.5" mounting bolts for Honeywell transmitter (4 required) - Order Part # 095-0411-100

2-Valve General Purpose Manifold-Remote Mount

Dimensions

Dimensions in inches (millimeters) are for reference only and are subject to change.

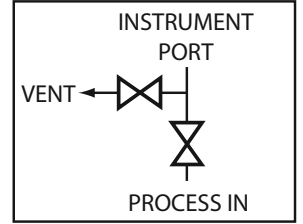

Front view

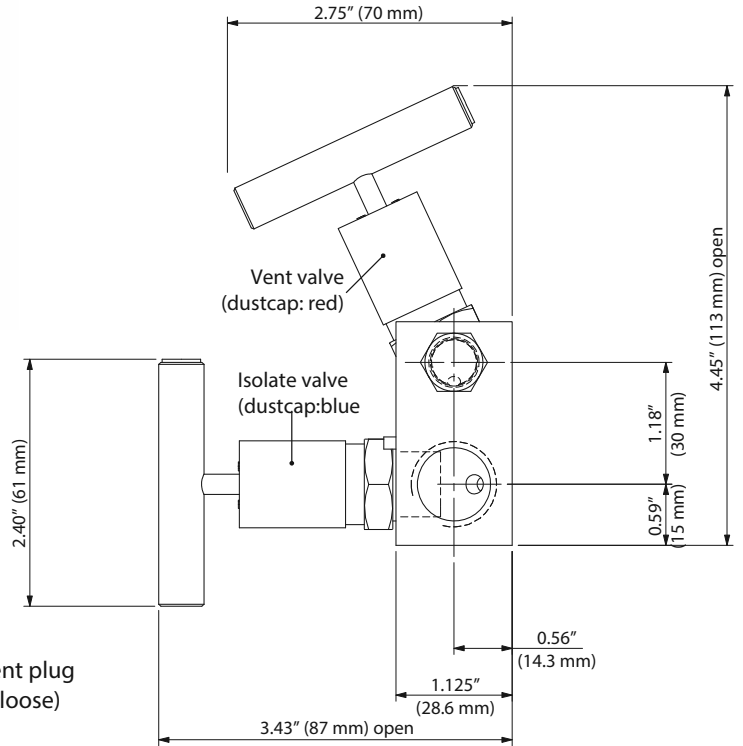
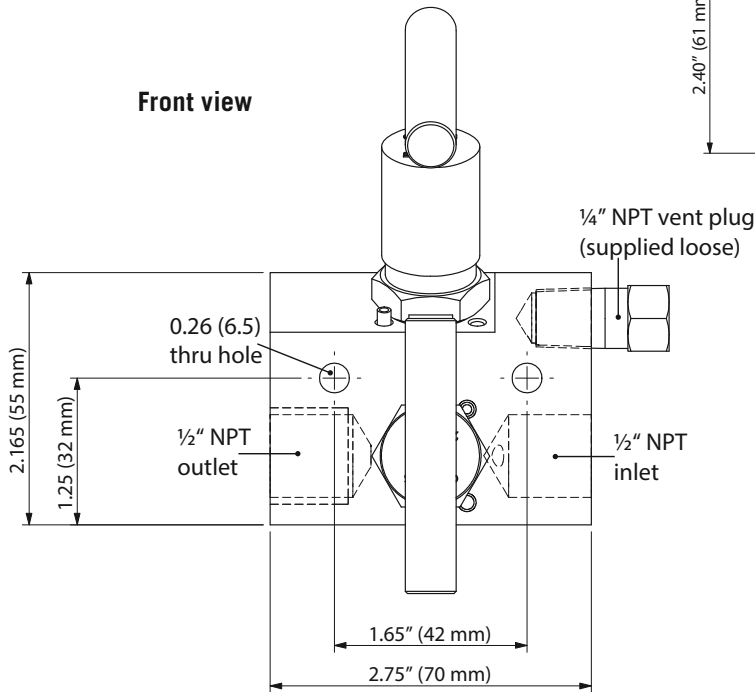

Right side view

How to Order

PART NUMBER	PACKING
GP823211F8YL	PTFE
GP823212F8YL	GRAFOIL®

Mounting kit-Order Part # 800000K2 (page 8)

3-Valve General Purpose Manifold-Direct Mount

Dimensions

Dimensions in inches (millimeters) are for reference only and are subject to change.

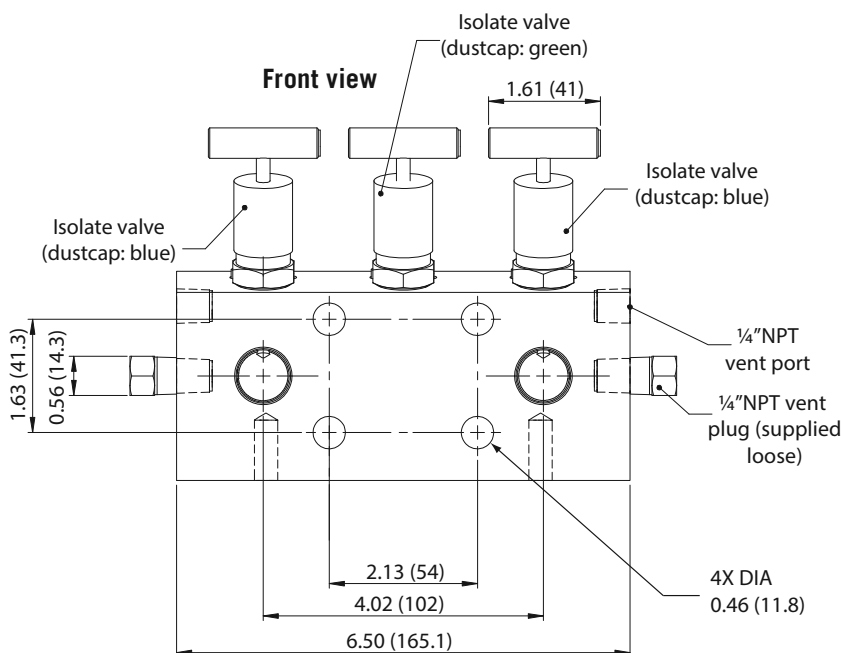
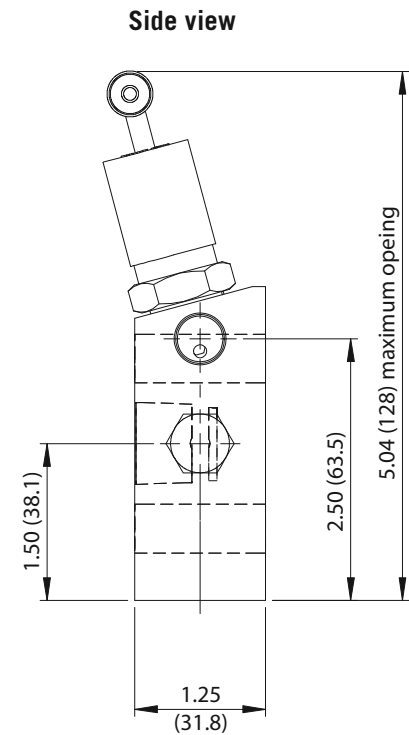
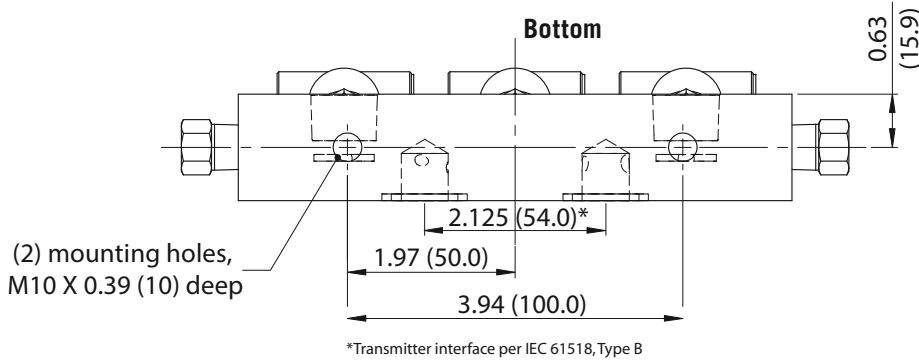
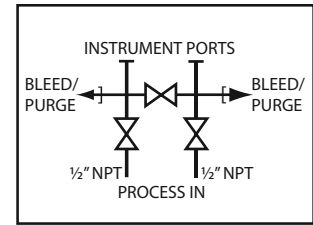

How to Order

PART NUMBER	PACKING
GP831211F8YL	PTFE
GP831212F8YL	GRAFOIL®

Mounting kit-Order Part # 800000K1 (page 8)
 1.5" mounting bolts for Honeywell transmitter
 (4 required) - Order Part # 095-0411-100

3-Valve General Purpose Manifold-Remote Mount

Dimensions

Dimensions in inches (millimeters) are for reference only and are subject to change.

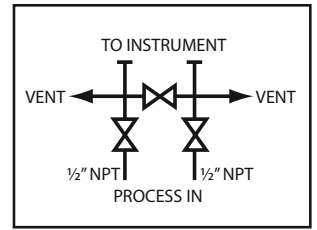

Top view

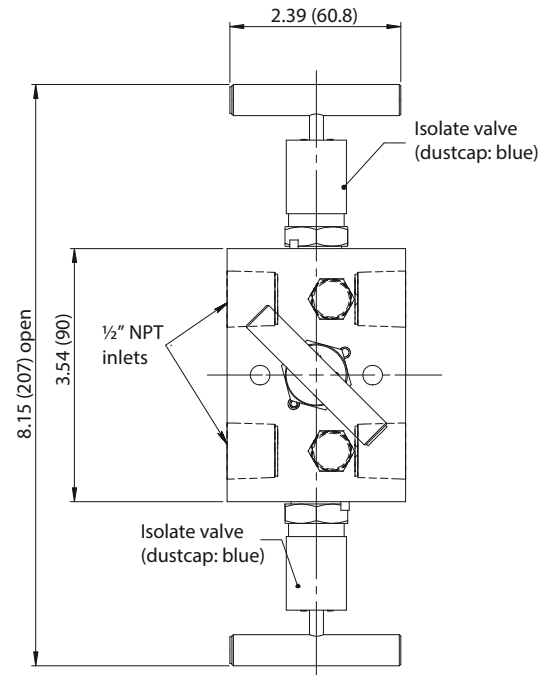

Side view

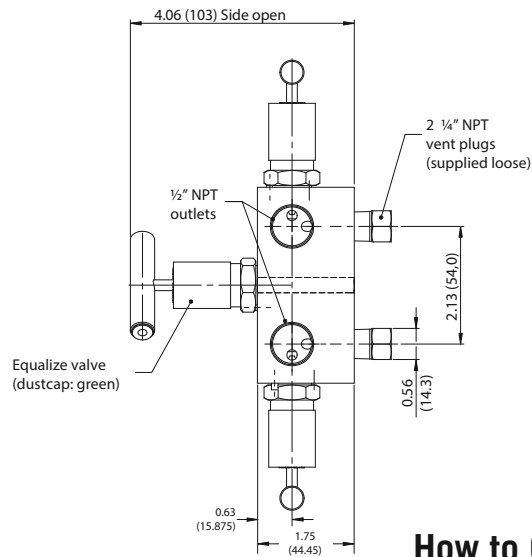
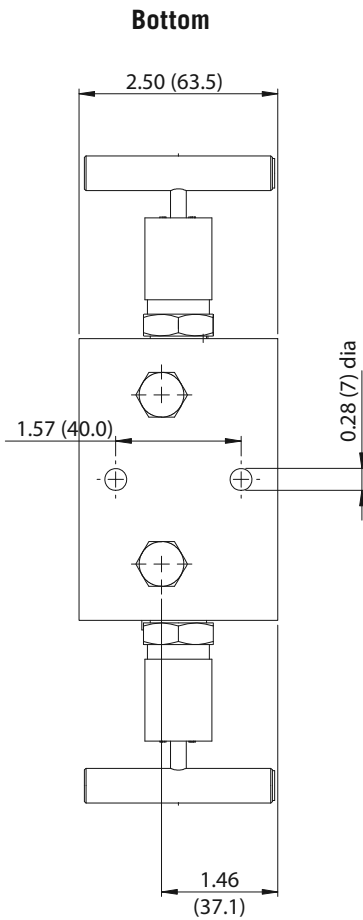

How to Order

PART NUMBER	PACKING
GP833211F8YL	PTFE
GP833212F8YL	GRAFOIL®

Mounting kit-Order Part # 800000K2 (page 8)

5-Valve General Purpose Manifold-Direct Mount

Dimensions

Dimensions in inches (millimeters) are for reference only and are subject to change.

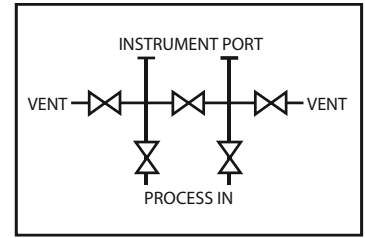

Side view

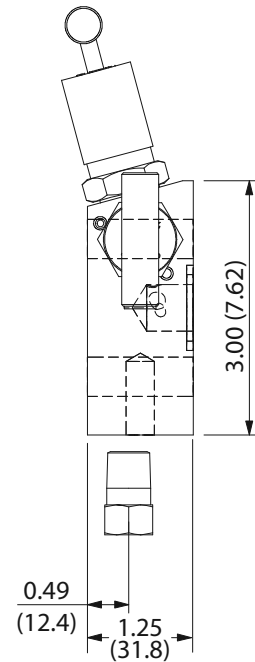

Front view

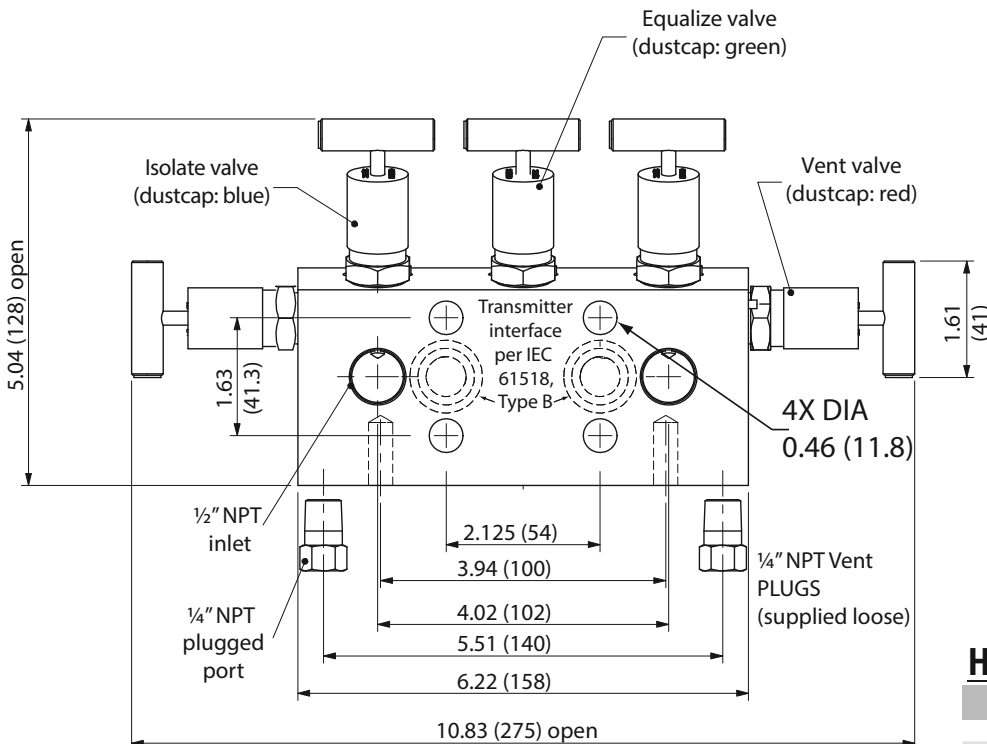

How to Order

PART NUMBER	PACKING
GP851211F8YL	PTFE
GP851212F8YL	GRAFOIL®

Mounting kit—Order Part # **800000K1** (page 8)
 1.5" mounting bolts for Honeywell transmitter
 (4 required) — Order Part # **095-0411-100**

5-Valve General Purpose Manifold-Remote Mount

Dimensions

Dimensions in inches (millimeters) are for reference only and are subject to change.

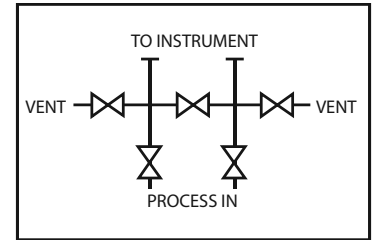

Right side view

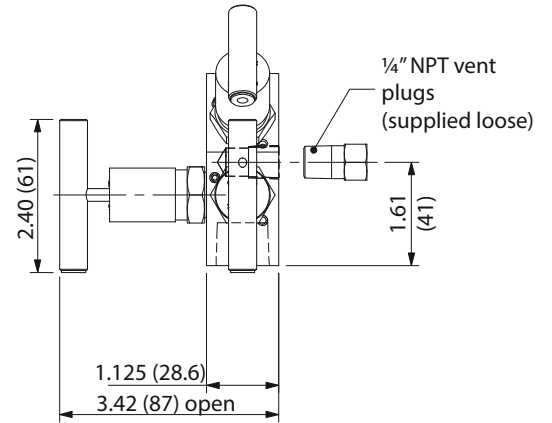

Back view

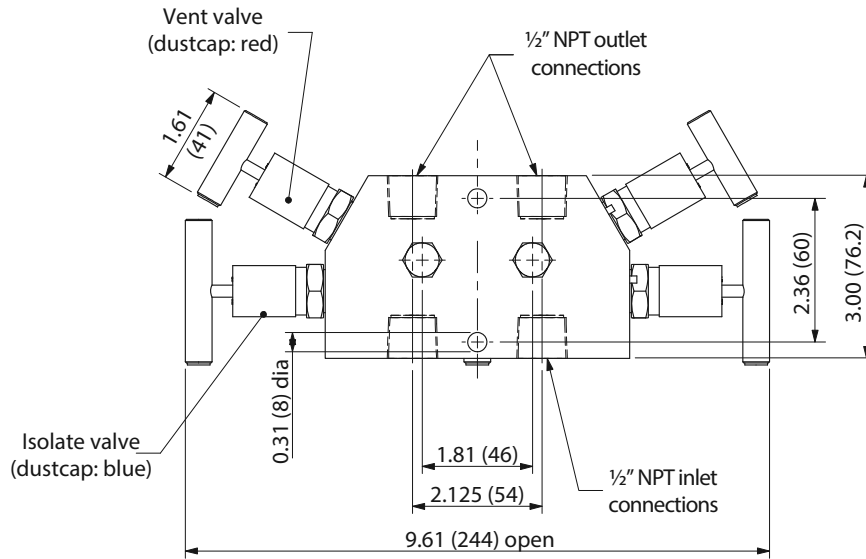

Top view

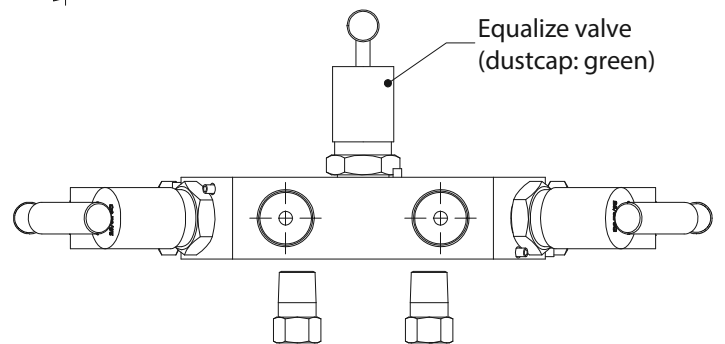

How to Order

PART NUMBER	PACKING
GP853211F8YL	PTFE
GP853212F8YL	GRAFOIL®

Mounting kit—Order Part # 800000K2 (page 8)

General Purpose Manifold Mounting Kits

800000K1 – For Direct Mount Models

Dimensions are in inches (millimeters) are for reference only and are subject to change.

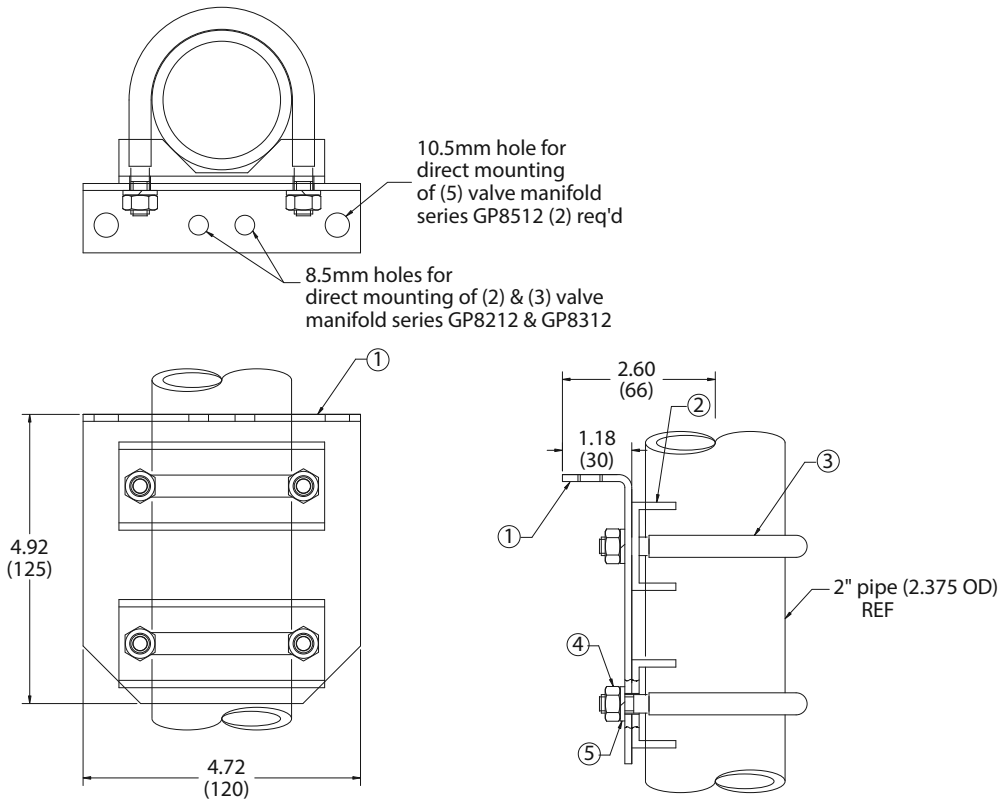

ITEM	TITLE	MATERIAL
1	Bracket	316 SS
2	Clamp Plate	316 SS
3	U-Bolt	316 SS
4	Nut, Hex	316 SS
5	Washer, Lock	316 SS

800000K2 – For Remote Mount Models

Dimensions are in inches (millimeters) are for reference only and are subject to change.

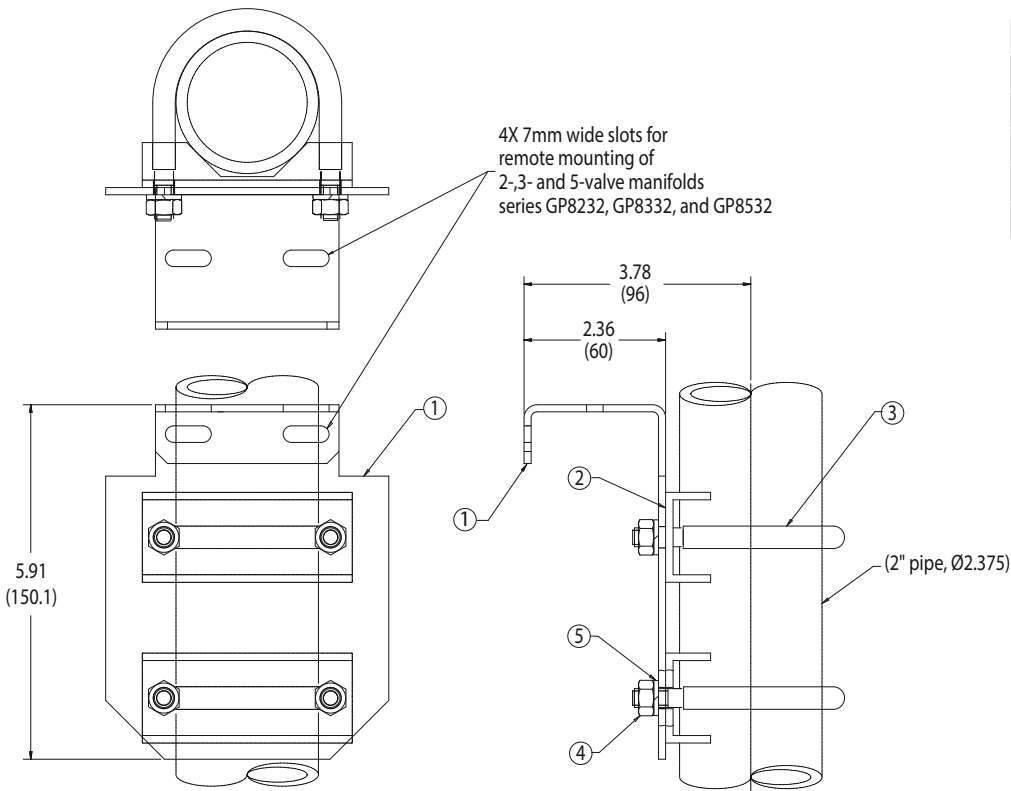

ITEM	TITLE	MATERIAL
1	Bracket	316 SS
2	Clamp Plate	316 SS
3	U-Bolt	316 SS
4	Nut, Hex	316 SS
5	Washer, Lock	316 SS



Trifold Needle Valve Manifold

The HOKE® 3-Valve Trifold manifold is designed for direct mounting to differential pressure transmitters having 2.125 inches (54 mm) center-to-center process connections.

Pipe by Flange

When direct coupling to orifice plate flanges is not desired, the pipe by flange Trifold Manifold allows for two ½" NPT process connections in addition to direct mounting of the transmitter.

Flange by Flange

When direct coupling to orifice plate flanges is required, the flange by flange Trifold Manifold mounts directly between the flange and the transmitter. If direct coupling to orifice plate flanges is not required, process futbol connectors may also be used.



instrument manifolds

Technical Data

MAXIMUM OPERATING PRESSURE	<i>Dyna-Pak/Metal Stem Tip</i>
	<ul style="list-style-type: none"> • 6000 psig (414 barg) -65° F to +150° F (-54°C to +66° C) • 3000 psig (307 barg) at +450° F (+232° C)
	<i>Graph-Lock/PTFE Wafer Packing</i>
	<ul style="list-style-type: none"> • 5000 psig (345 barg) -60° F to +600° F (-51°C to +316° C) • 3000 psig (307 barg) at +450° F (+232° C)
OPERATING TEMPERATURE RANGE	<i>Dyna-Pak/Metal Stem Tip</i>
	<ul style="list-style-type: none"> • -65° F to +450° F (-54°C to +232° C)
	<i>Graph-Lock/PTFE Wafer Packing</i>
	<ul style="list-style-type: none"> • -60° F to +600° F (-51°C to +316° C)

Features & Benefits

- Purge ports are provided on the process side of block valves for applications requiring continuous purging.
- Bleed or vent ports on the instrument side of the block valves.
- Dyna-Pak PTFE or high-temperature 600° F (316° C) Graph-lock/PTFE wafer packing is standard.
- Bonnet locks prevent accidental disengagement of the bonnet.
- Non-rotating hardened metal stem tip.
- Integral backseats on all valve stems prevent accidental removal.
- Mounting bolts and PTFE gaskets are standard.
- Packing below stem threads prevents process liquids from contaminating or washing away the thread lubricants.
- Special High Tolerance NPT Thread

Pressure Temperature Curves

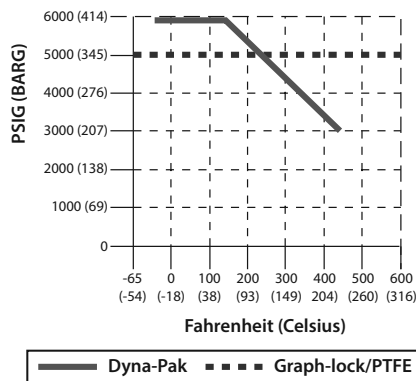

Trifold Needle Valve Manifold– Pipe by Flange

Special Application Manifolds

Dimensions and Materials

Dimensions in inches (millimeters) are for reference only and are subject to change

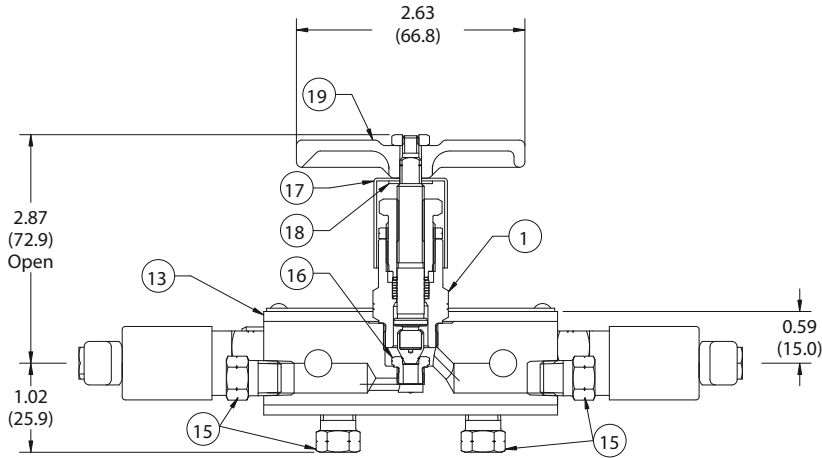

	DESCRIPTION	MATERIAL
1	HOUSING	316 stainless steel
2	PACKING NUT	316 stainless steel
3	LOCK NUT	316 stainless steel
4	WASHER	316 stainless steel
5	WAFER	PPTFE tape
6	WASHER	316 stainless steel
7	SPACER	316 stainless steel
8	STEM	316 stainless steel
9	DISC	17-7PH stainless steel
10	STEM POINT	17-4PH stainless steel
11	WASHER	PPTFE
12	SPRING PIN	302 stainless steel
13	MANIFOLD BLOCK	316 stainless steel
14	CAP SCREW	18-8 stainless steel
15	PIPE PLUG	316 stainless steel
16	SEAT INSERT	316 stainless steel
17	CAP LUG	Polyethylene
18	WASHER	304 stainless steel
19	HANDLE	316 stainless steel

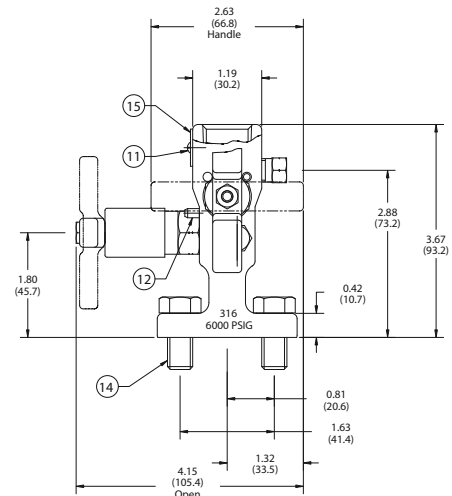
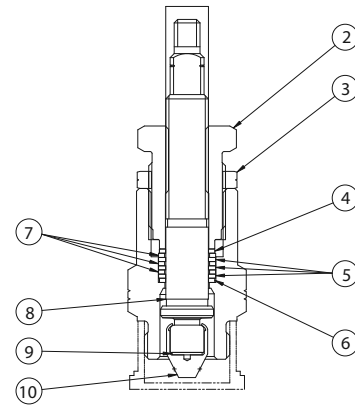
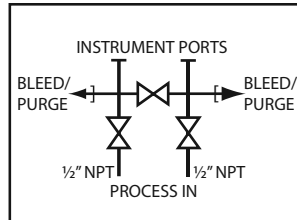
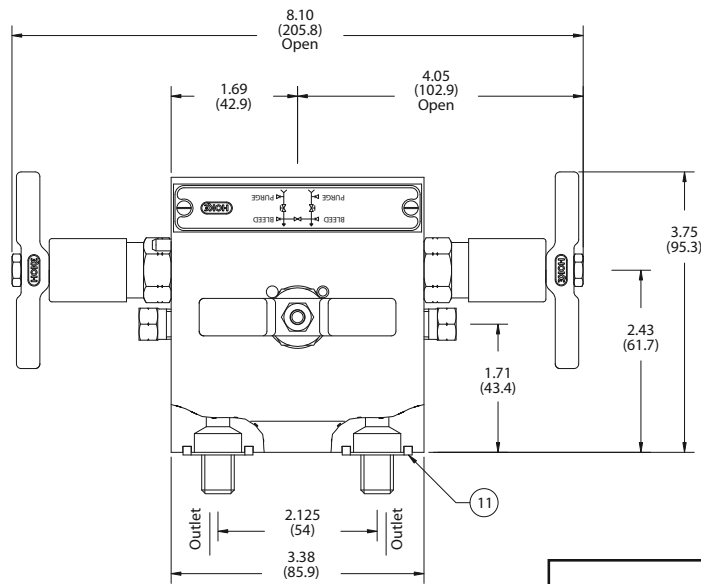

How to Order Trifold Pipe by Flange

CONNECTIONS		PART NUMBER	STEM POINT	PACKING
PROCESS	INSTRUMENT			
1/2" Female NPT	Flange	8122F8Y	Non-rotating 17-4PH	Dyna-Pak
1/2" Female NPT	Flange	8128F8Y	Non-rotating 17-4PH	Graph-lock/ PTFE wafers

Mani-Mount mounting module see page 17 for details (available for **8122F8Y** only)

Trifold Needle Valve Manifold– Flange by Flange

Special Application Manifolds

Dimensions and Materials

Dimensions are in inches (millimeters) are for reference only and are subject to change

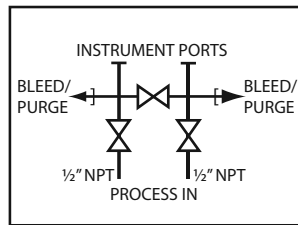
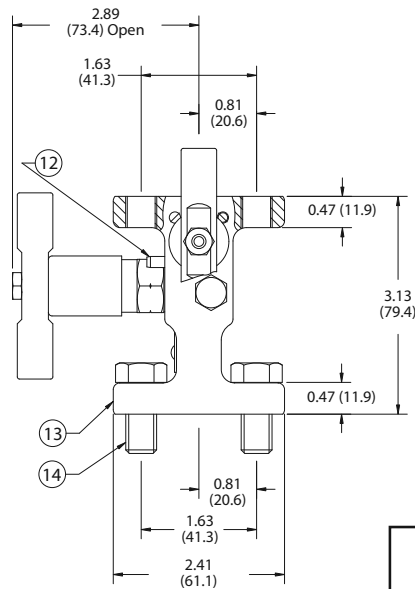
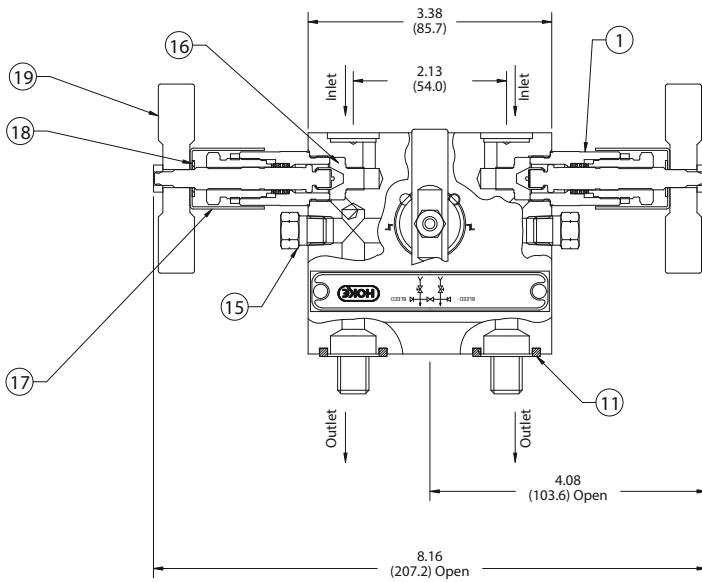

	DESCRIPTION	MATERIAL
1	HOUSING	316 stainless steel
2	PACKING NUT	316 stainless steel
3	LOCK NUT	316 stainless steel
4	WASHER	316 stainless steel
5	WASHER	PPTFE tape
6	WASHER	316 stainless steel
7	SPACER	316 stainless steel
8	STEM	316 stainless steel
9	DISC	17-7PH stainless steel
10	STEM POINT	17-4PH stainless steel
11	WASHER	PPTFE
12	SPRING PIN	302 stainless steel
13	MANIFOLD BLOCK	316 stainless steel
14	CAP SCREW	18-8 stainless steel
15	PIPE PLUG	316 stainless steel
16	SEAT INSERT	316 stainless steel
17	CAP LUG	Polyethylene
18	WASHER	304 stainless steel
19	HANDLE	316 stainless steel

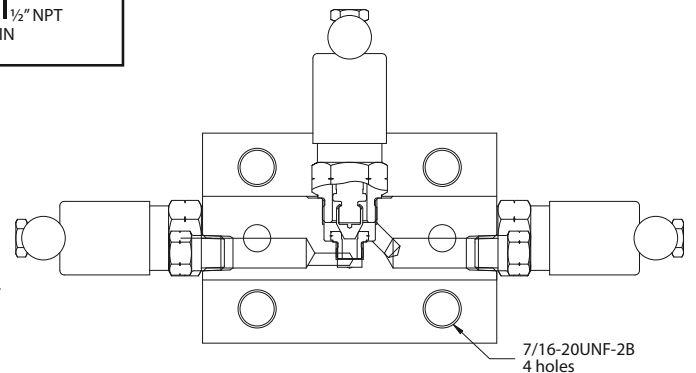
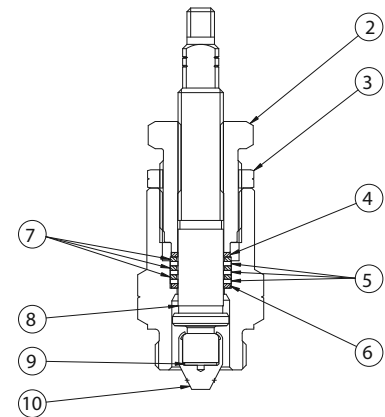

How to Order Trifold Flange by Flange

CONNECTIONS		PART NUMBER	STEM POINT	PACKING
PROCESS	INSTRUMENT			
Flange	Flange	8132YY	Non-rotating 17-4PH	Dyna-Pak
Flange	Flange	8138YY	Non-rotating 17-4PH	Graph-lock/ PTFE wafers



Rotofold Ball Valve Manifold

The HOKE® Rotofold ball valve manifold has a unique design that utilizes quarter turn ball valves for blocking process impulse lines and performing equalizing functions. They also provide easy rod through of all passages when clean-out is necessary. PCPTFE seats and PPTFE stem packing are easily replaced if maintenance is required. The pipe by flange Rotofold design allows the manifold to be directly mounted to integral orifice transmitters by simply reversing the flanges and flange fittings. The pipe by pipe Rotofold design allows the manifold to be remotely mounted separately from the process.

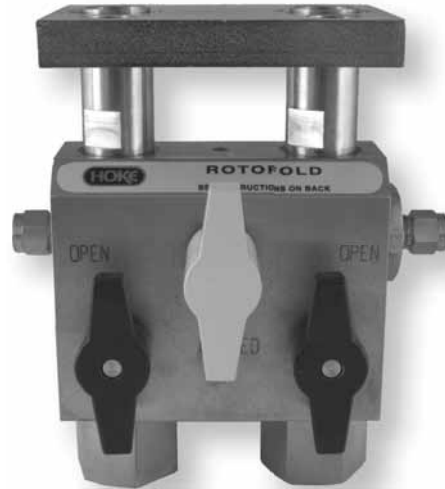

instrument manifolds

Technical Data

MAXIMUM OPERATING PRESSURE	6000 psig (414 barg)
	-65° F to +150° F (-54°C to +66° C)
OPERATING TEMPERATURE RANGE	400 psig @ +300° F (28 barg @ +149° C)
	0° F to +300° F (-18°C to +149° C)

Pressure Temperature Curves

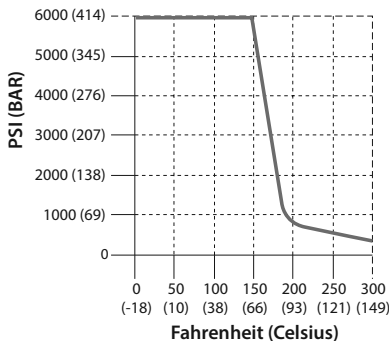

Features & Specifications

- Flange can be reversed for direct mounting to an integral orifice type transmitter.
- Connections on instrument side of block valves for bleeding and venting.
- Replaceable PCPTFE seats on all valves provide longer service life.
- All media passages can be rodded for easy cleaning.
- ¼ turn handle provides visual indication of valve mode.
- Mounting bolts and PTFE gaskets are standard with flange models.
- Cam handles provide error-proof sequencing of valves.
- Mani-Mount mounting kit available for NPT pipe style (see Mani-mount mounting system, page 17)
- Special High Tolerance NPT Thread

Cam-Valve Interlocking Sequencing Handles

The correct sequencing of opening and closing manifold valves is critical to eliminating pressure transmitter damage due to over ranging. By attaching cams to the equalizing and block valve handles, the inter-locking design assures proper initial service and transmitter zeroing during calibration.

Cam kit **8200KS** can be field installed or factory assembled to the manifold at time of order. For factory assembled, add part number **8200KS** to the end of the manifold part number.

Rotofold Ball Valve Manifold - Pipe by Flange

Special Application Manifolds

Dimensions and Materials

Dimensions are in inches (millimeters) are for reference only and are subject to change

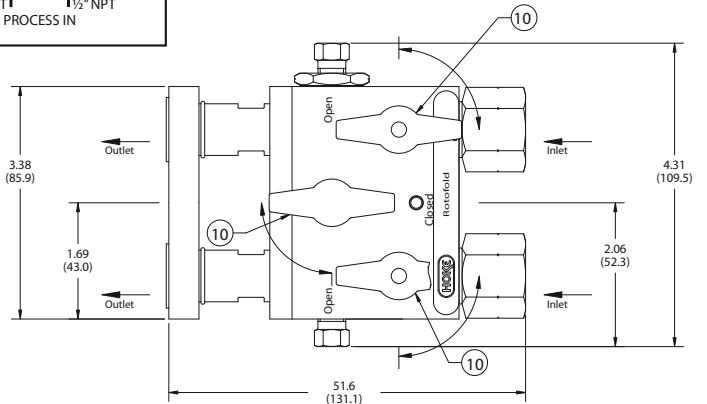
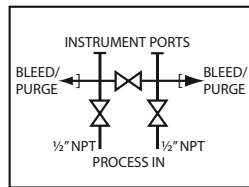
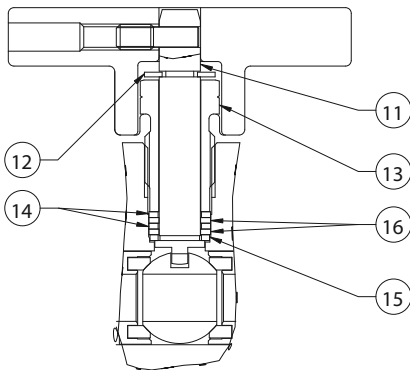
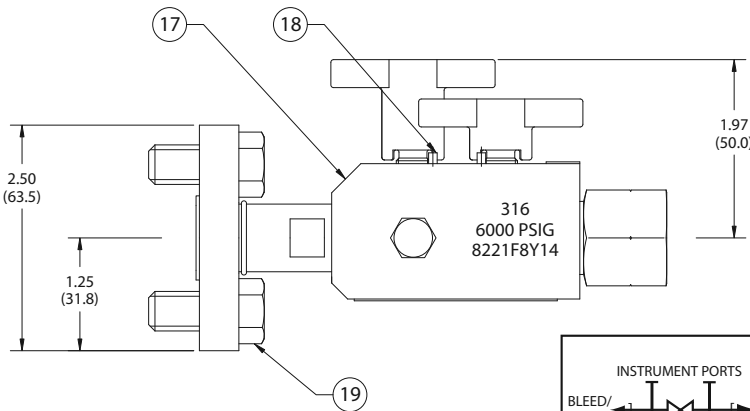
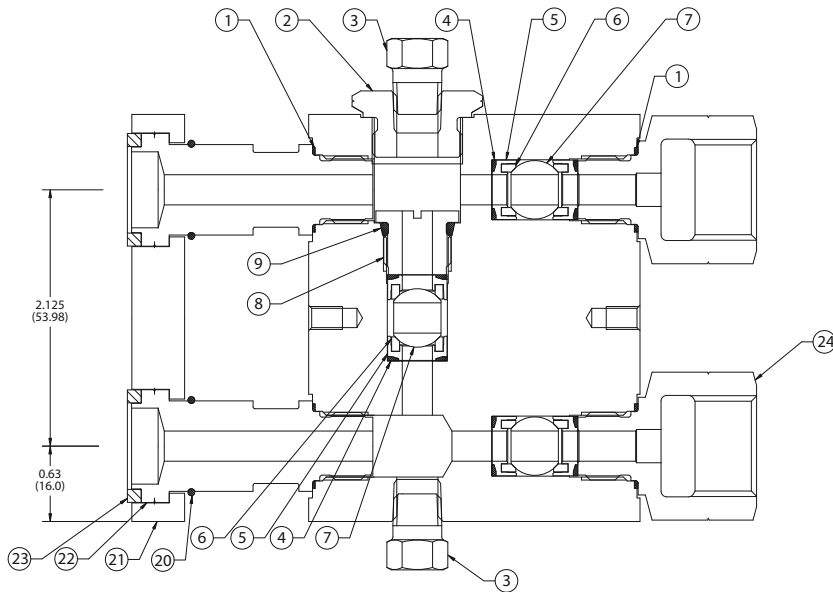

	DESCRIPTION	MATERIAL
1	PLUG WASHER	PPTFE
2	VENT FITTING	316 stainless steel
3	PIPE PLUG	316 stainless steel
4	WASHER	Viton®
5	SEAT RETAINER	316 stainless steel
6	SEAT	PCPTFE
7	BALL	316 stainless steel
8	INSERT	316 stainless steel
9	O-RING	Fluorelastomer
10	HANDLE	Aluminum alloy 360
11	STEM	316 stainless steel
12	RETAINING RING	PH15-7MO
13	STEM RETAINER	316 stainless steel
14	SHIM WASHER	316 stainless steel
15	SHIM WASHER	316 stainless steel
16	SHIM WASHER	PPTFE
17	MANIFOLD BODY	316 stainless steel
18	SPIRAL PIN	302 stainless steel
19	CAP SCREW	Carbon Steel
20	RETAINING RING	302 stainless steel
21	FLANGE	Carbon Steel
22	FLANGE CONNECTOR	316 stainless steel
23	WASHER	PPTFE
24	END FITTING	316 stainless steel

How to Order Rotofold-Pipe by Flange

CONNECTIONS			PART NUMBER
BODY OUTLET STYLE	INLET PROCESS	OUTLET INSTRUMENTATION	
Flange	1/2" Female NPT	Flange	8221F8Y

Cam-valve sequencing handles order Part # **8200K5**

Mani-Mount mounting module - see page 17 for details (available for **8221F8Y** only)

Rotofold Ball Valve Manifold - Pipe by Pipe

Special Application Manifolds

Dimensions and Materials

Dimensions are in inches (millimeters) are for reference only and are subject to change

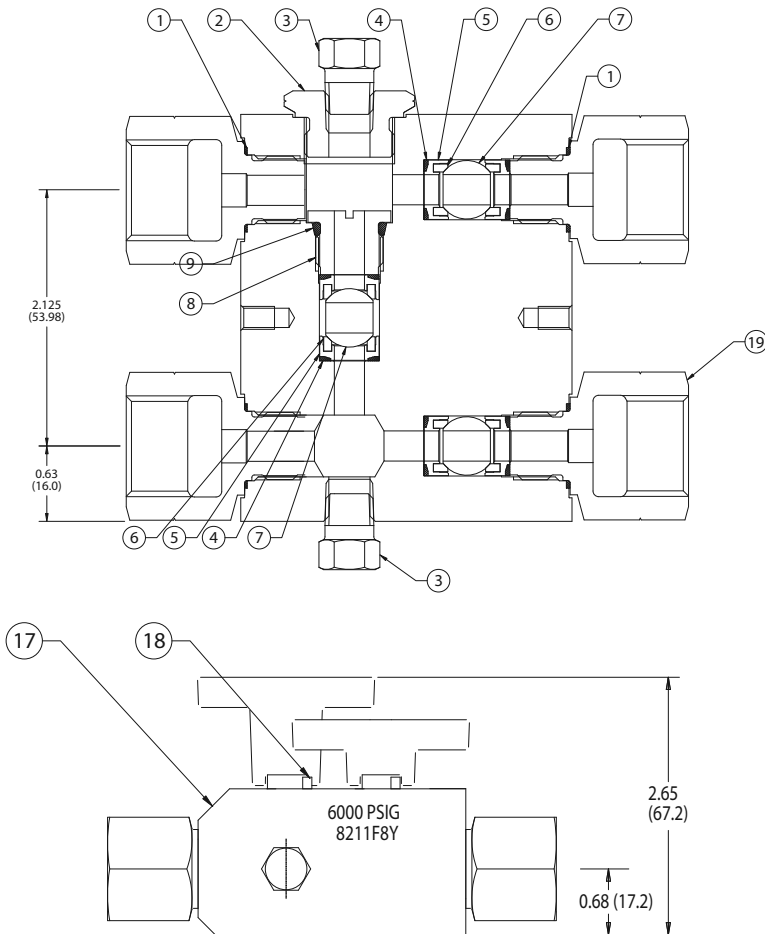

	DESCRIPTION	MATERIAL
1	PLUG WASHER	PPTFE
2	VENT FITTING	316 stainless steel
3	PIPE PLUG	316 stainless steel
4	WASHER	Viton®
5	SEAT RETAINER	316 stainless steel
6	SEAT	PCPTFE
7	BALL	316 stainless steel
8	INSERT	316 stainless steel
9	O-RING	Fluorelastomer
10	HANDLE	Aluminum alloy 360
11	STEM	316 stainless steel
12	RETAINING RING	PH15-7MO
13	STEM RETAINER	316 stainless steel
14	SHIM WASHER	316 stainless steel
15	SHIM WASHER	316 stainless steel
16	SHIM WASHER	PPTFE
17	MANIFOLD BODY	316 stainless steel
18	SPIRAL PIN	302 stainless steel
19	END FITTING	316 stainless steel

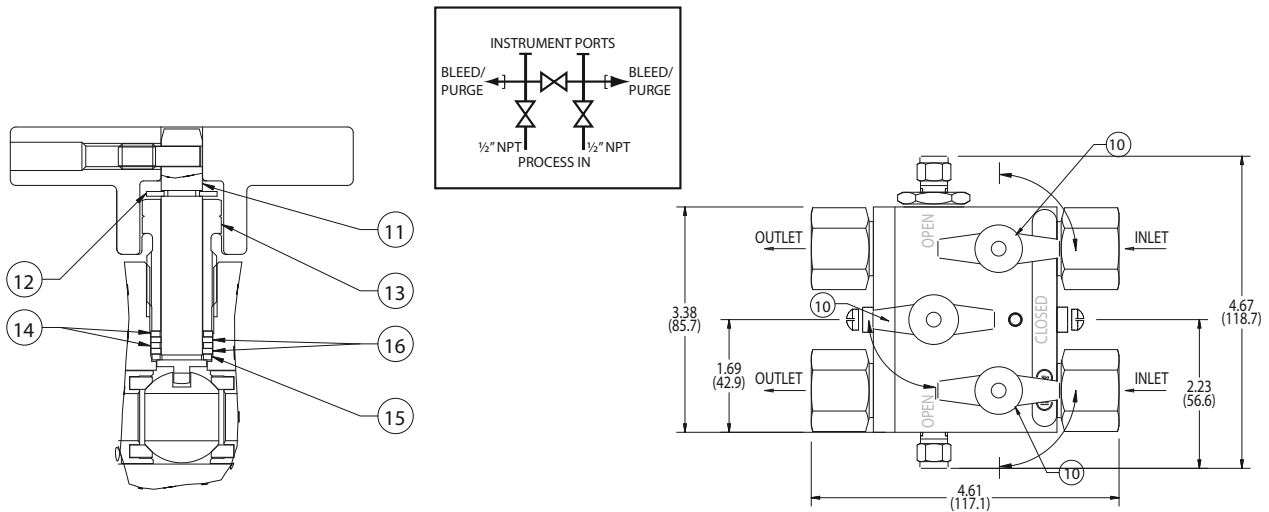

How to Order Rotofold-Pipe by Pipe

CONNECTIONS			PART NUMBER
BODY OUTLET STYLE	INLET PROCESS	OUTLET INSTRUMENTATION	
NPT Pipe	1/2" Female NPT	1/2" Female NPT	8211F8Y

Cam-valve sequencing handles order Part # **8200K5**

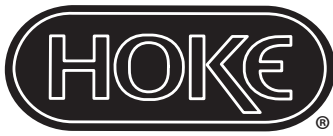

Pentafold 5-Valve Manifold

The HOKE® Pentafold 5-valve manifold is specifically designed for use with differential pressure transmitters when applied to gas flow measurement. This manifold design uses two PCPTFE seated ball valves and three needle valves with non-rotating PCPTFE stem tips as bypass or equalizing valves and vent valves. The two by-pass valves assure no leakage across the high and low side of the orifice meter for critical gas flow measurement. The pipe by pipe Pentafold design allows the manifold to be mounted away from the process but close to a differential pressure transmitter through the use of impulse piping.



Technical Data

MAXIMUM OPERATING PRESSURE	6000 psig (414 barg)
	-20° F to +150° F (-29°C to +66° C)
OPERATING TEMPERATURE RANGE	400 psig @ +300° F (28 barg @ +149° C)
	0° F to +300° F (-18°C to +149° C)

Features & Benefits

- Static or vent ports provided on instrument side.
- Replaceable ball seats and stem tips extend service life, reducing cost.
- Threaded mounting hole provided on all models.
- Single manifold block has fewer potential leak paths than individually assembled valves.
- PTFE standard packing in all valves.
- Special High Tolerance NPT Thread

Pressure Temperature Curves

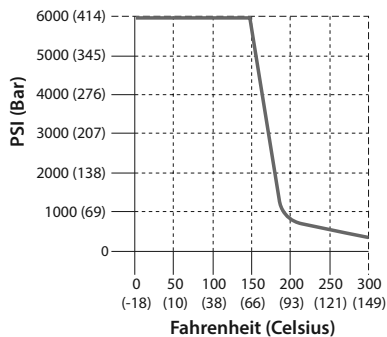

instrument manifolds

Pentafold 5-Valve Manifold

Special Application Manifolds

Dimensions and Materials

Dimensions are in inches (millimeters) are for reference only and are subject to change

	DESCRIPTION	MATERIAL
1	WASHER	Fluorelastomer
2	SEAT RETAINER	316 stainless steel
3	SEAT	PCPTFE
4	BALL	316 stainless steel
5	PLUG WASHER	PPTFE
6	END FITTING	316 stainless steel
7	HANDLE	316 stainless steel
8	PACKING NUT	316 stainless steel
9	PACKING	PPTFE
10	SPACER	316 stainless steel
11	HOUSING	316 stainless steel
12	SPINDLE	316 stainless steel
13	SEAT RETAINER	316 stainless steel
14	SEAT	PCPTFE
15	STEM	316 stainless steel
16	RETAINING RING	Stainless steel
17	STEM RETAINER	316 stainless steel
18	SHIM WASHER	316 stainless steel
19	SHIM WASHER	316 stainless steel
20	SHIM WASHER	PPTFE
21	HANDLE	Aluminum alloy 360
22	BODY	316 stainless steel
23	SEAT RETAINER	316 stainless steel
24	SEAT	PCPTFE
25	SCREW	18-8 stainless steel
26	O-RING	Fluorelastomer
27	SPRING PIN	302 stainless steel

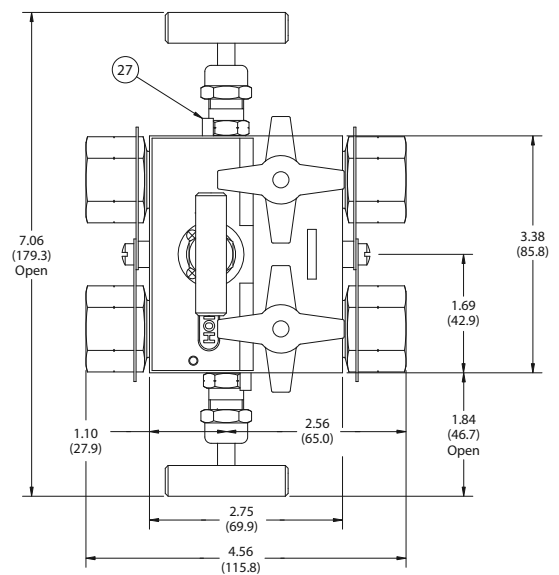
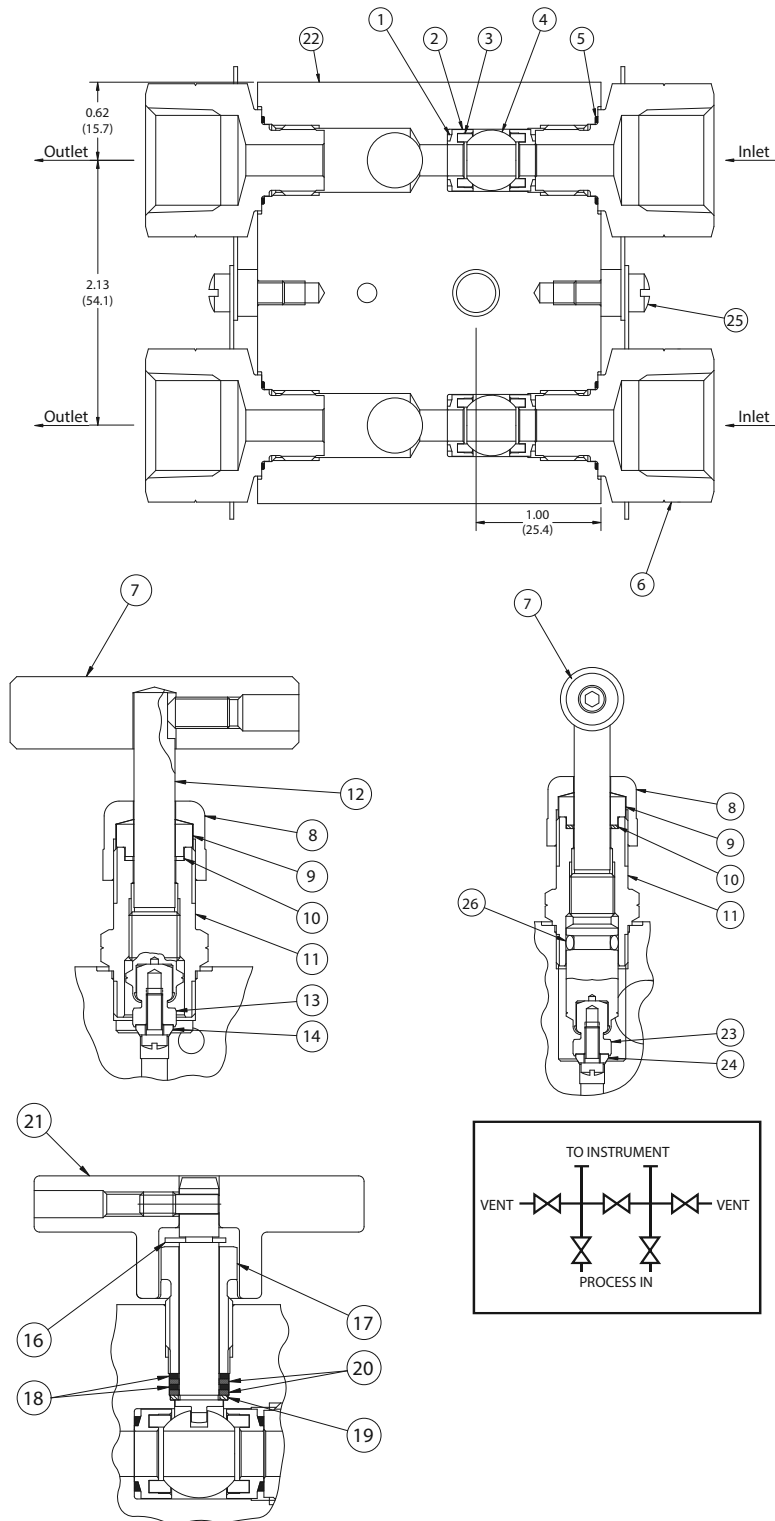

How to Order Pentafold

CONNECTIONS		PART NUMBER
INLET PROCESS	OUTLET INSTRUMENTATION	
1/2" Female NPT	Flange	8613F8Y

Manifold Accessories

Mani-Mount Manifold Mounting System*

This installation method provides for rigid mounting of a Trifold or Rotofold manifold to a 2 inch pipe stand instead of a differential pressure transmitter. Only the manifold is mounted during construction, which permits storage of the transmitter until needed. The Mani-Mount not only provides a simple universal mounting solution, but also converts the manifold to a single flange design for direct mounting to the transmitter. The Mani-Mount can be used with any standard transmitter having 2 1/8" center to center process connections. Typical installation hardware costs are reduced because transmitter mounting brackets are not necessary.

*Available for Special Application Trifold **8122F8Y** and Rotofold **8221F8Y** models only

Features & Benefits

- Allows for rigid mounting of the manifold, instead of the transmitter.
- Simple universal mounting system for vertical, horizontal or either side of 2 inch pipe stand.
- Only the manifold needs to be mounted during construction; the transmitter can be securely stored until final installation.
- Transmitter mounting bracket is not necessary, reducing costs.
- Provides easy access to the transmitter by loosening 4 flange bolts.
- Fast installation process, saving time and money on costly conventional installations.
- Converts the manifold to a single flange style for direct mounting to the transmitter cell.
- Special High Tolerance NPT Thread

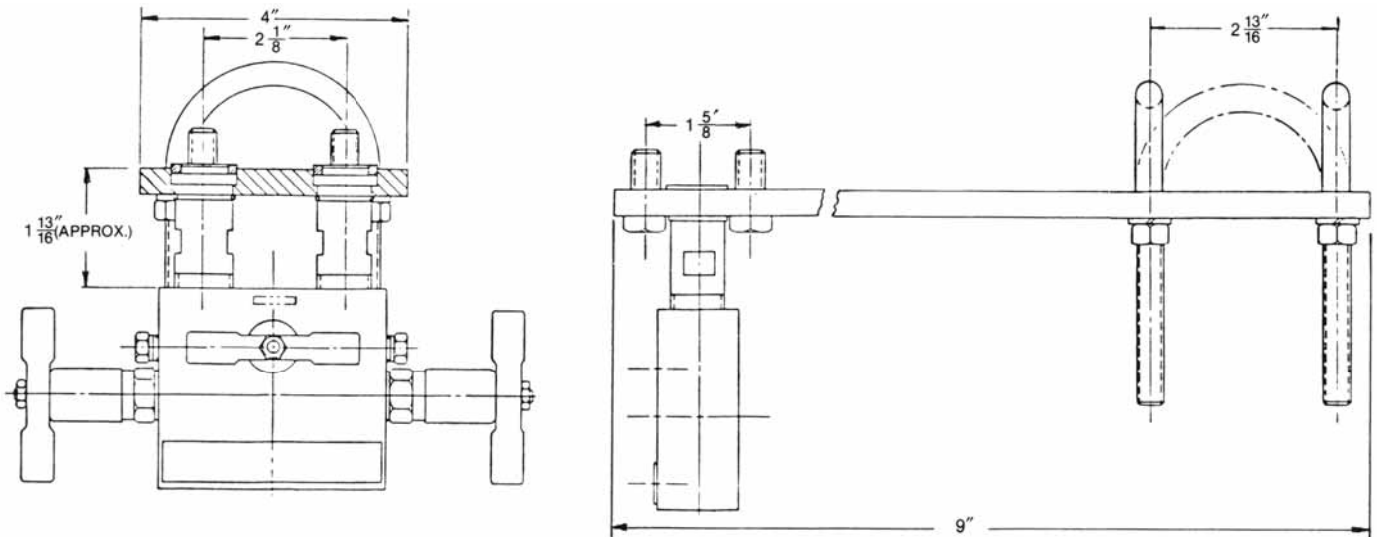

How to Order Kit*

PART NUMBER

8200K9

* manifold not included

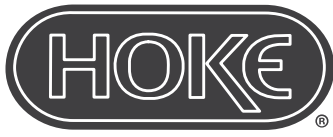

The Small Bore Instrumentation Specialists

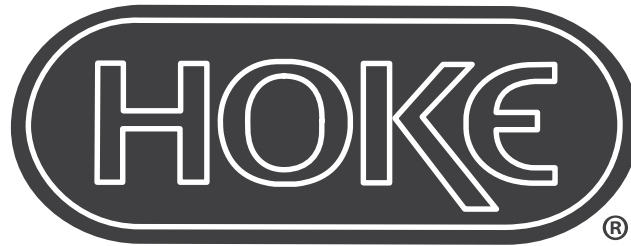

We specialize in small bore instrumentation products up to 2" that deliver benchmark performance quality & safety; provide the broadest array of superior alloy offerings in the market; decades of proven success in a wide range of industries; a roster of "who's who" customers & projects globally; original "Best Solution" engineering & designs; and are focused on continuous improvement in all aspects of our business.

Proudly Distributed By:



Authorized distributor in Iraq:
DHIAA AL-AMEEN CO., LTD. FOR GENERAL CONTRACTING LTD
Al-Saadi Street - opposite the Central Library
Basra-Iraq
supply department:
supply@dhialameen.com
+9647853807448
www.dhialameen.com

CRANE INSTRUMENTATION &
SAMPLING Inc.
405 Centura Ct.
Spartanburg, SC 29305, USA
Tel: 1-864-574-7966
PO Box 4866, Spartanburg, SC
29305-4866 USA

Crane Co., and its subsidiaries cannot accept responsibility for possible errors in catalogues, brochures, other printed materials, and website information. Crane Co. reserves the right to alter its products without notice, including products already on order provided that such alteration can be made without changes being necessary in specifications already agreed. All trademarks in this material are the property of the Crane Co. or its subsidiaries. The Crane and Crane brands logotype (CENTER LINE®, COMPAC-NOZ®, CRANE®, DEPA® & ELRO®, DOPAK®, DUO-CHEK®, FLOWSEAL®, GYROLOK®, GO REGULATOR®, HOKE®, JENKINS®, KROMBACH®, NOZ-CHEK®, PACIFIC VALVES®, RESISTOFLEX®, REVO®, SAUNDERS®, STOCKHAM®, TEXAS SAMPLING®, TRIANGLE®, UNI-CHEK®, VALVES®, WTA®, and XOMOX®) are registered trademarks of Crane Co. All rights reserved.